

Instruction Manual

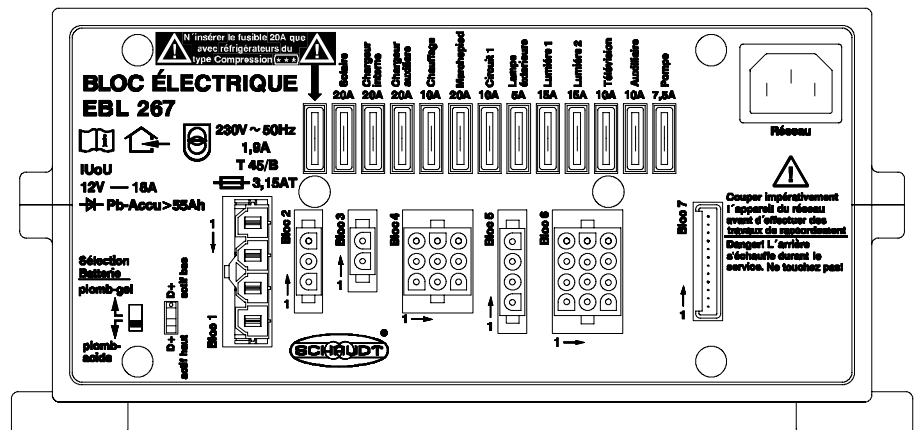

Electroblock EBL 267 A

Table of contents

1	Safety information	2
1.1	Meaning of safety symbols	2
1.2	General safety information	2
2	Introduction	3
3	Operation	3
3.1	Starting up the system	3
3.2	Changing the battery	4
3.3	System faults	5
3.4	Closing down the system	7
4	Application and functions in detail	8
4.1	Battery functions	9
4.2	Additional functions	10
5	Maintenance	10
	Appendix	11

1 Safety information

1.1 Meaning of safety symbols



▲ DANGER!

Failure to heed this warning may result in death or serious injury.



▲ WARNING!

Failure to heed this warning may result in personal injuries.



▲ ATTENTION!

Failure to heed this warning may result in damage to the device or connected consumers.

1.2 General safety information

The device is state-of-the-art and complies with approved safety regulations. Nonetheless, personal injuries or damage to the device may occur if the safety instructions contained herein are not followed.

Ensure that the device is in perfect working order before use.

Any technical faults which may impact personal safety or the safety of the device must be rectified immediately by qualified personnel.



▲ DANGER!

230 V mains voltage carrying parts.

Danger of death due to electric shock or fire:

- Do not carry out maintenance or repair work on the device.
- If cables or the device housing are damaged, no longer use the device and isolate from the power supply.
- Ensure that no liquids enter the device.



▲ WARNING!

Hot components!

Burns:

- Only change blown fuses when the device is completely de-energised.
- Only replace blown fuses once the cause of the fault has been identified and rectified.
- Never bypass or repair fuses.
- Only use original fuses rated as specified on the device.
- Device parts can become hot during operation. Do not touch.
- Never store heat sensitive objects close to the device (e.g. temperature sensitive clothes if the device has been installed in a wardrobe).

2 Introduction

This instruction manual contains important information for safe operation of the device. Make sure you read and follow the safety instructions provided.

The instruction manual should be kept in the vehicle at all times. Ensure that other users are made aware of the safety regulations.

3 Operation

The electrobloc is operated exclusively by the IT .../LT ... control and switching panel connected.

Operation of the EBL 267 A electrobloc is not required for daily use.

Settings only have to be configured once if the battery type is changed (lead-acid or lead-gel), during initial start-up or when retrofitting accessories (see section 3.2 and installation instructions for EBL 267 A).

3.1 Starting up the system



▲ ATTENTION!

Incorrect electrobloc settings.

Damage to connected devices. Therefore prior to starting:

- Ensure the leisure battery is connected.
- Make sure the battery selector switch (fig. 3, pos. 9) is set to the correct position for the battery inserted.
- Make sure the AES fuse (fig. 3, pos. 11, with 20 A fuse and labelled with a warning system) is only used in conjunction with a connected AES refrigerator. Otherwise the leisure battery may totally discharge. Damage to the battery is possible.

Use the 12 V main switch (see instruction manual of relevant control and switch panel) to switch on/off all the consumers and the control and switch panel.

The outputs are exceptions:

- | | |
|-------------------------------|----------------------------|
| ● Circuit 1 | ● Additional heater (50 W) |
| ● Heater | ● Step |
| ● AES/compressor refrigerator | ● Awning light |

These outputs are not disabled by the main switch of the IT .../LT ... control and display panel.

For further information, see operating instructions of the IT .../LT ... control and switch panel.

Generator operation and passenger vehicle ferries



▲ ATTENTION!

Exceeding the threshold values of the 230 V mains supply!

Damage to the electrobloc, 12 V consumers or connected devices:

- It is essential that the generator conforms to the specifications of the mains supply.
- Only connect up the generator when it is running smoothly.
- Do not connect the electrobloc to the mains supply on board passenger vehicle ferries (correct mains supply is not always guaranteed on board these ferries).

3.2 Changing the battery



▲ ATTENTION!

Use of incorrect battery types or incorrectly rated batteries.

Damage to the battery or devices connected to the electrobloc:

- Batteries should only be changed by qualified personnel.
- Follow the instructions provided by the battery manufacturer.
- Only connect the electrobloc to 12 V power supplies with rechargeable 6-cell lead-gel or lead-acid batteries. Do not use any unsuitable battery types.



▲ Only batteries of the same type and capacity should normally be used, i.e. same as those installed by the manufacturer.

▲ It is possible to swap lead-acid batteries with lead-gel batteries. However, swapping from lead-gel batteries to lead-acid batteries is only possible in certain circumstances. Contact the vehicle manufacturer for more information.

Changing the battery

▶ Electrically disconnect the battery from the electrobloc. To do this, enable battery isolation on the IT .../LT control and switch panel (also see section 3.1).

▶ Replace battery.

▶ After changing the battery, recheck which type of battery has been inserted.



▲ DANGER!

Incorrect setting of the battery selector switch.

Risk of explosion due to build up of explosive gases:

- Set the battery selector switch to the correct position.

▶ Disconnect the electrobloc from the mains before adjusting the battery selector switch.

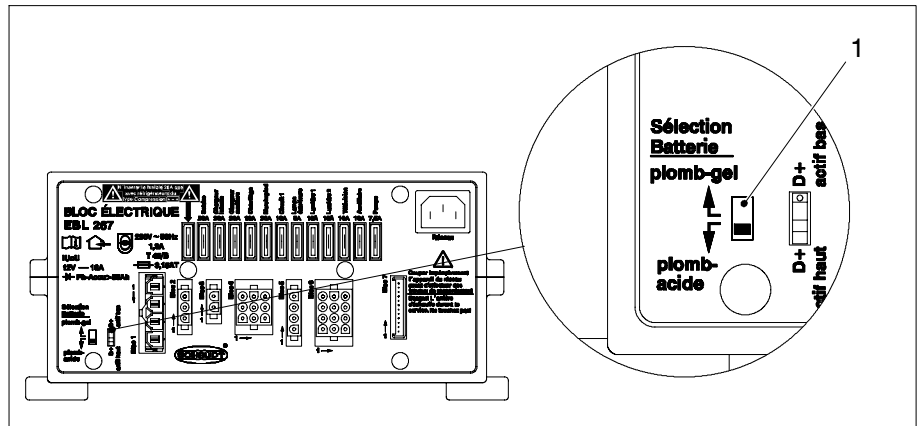

Fig. 1 Battery selector switch

- ▶ Set the battery selector switch (fig. 1, pos. 1) to the correct position using a thin object (such as a ballpoint pen):
 - Lead-gel battery: Set the battery selector switch to "Lead-gel".
 - Lead-acid battery: Set the battery selector switch to "Lead-acid".

Starting up the system ▶ Start up the system as described in section 3.1.

3.3 System faults

Flat vehicle fuses A fault in the power supply system is usually caused by a blown fuse.

Please contact our customer service department if you cannot rectify the fault using the following table.

If this is not possible, e.g. if you are abroad, you can have the electrobloc repaired at a specialist workshop. Please note that the warranty will become void if incorrect repair work is carried out. Schaudt GmbH shall not accept liability for any damages resulting from such repairs.

Polyswitch fuses The following functions are protected by a polyswitch fuse:

- 12 V indicator
- Battery 1
- Output D+

If a fault occurs here, the electrobloc must be switched off for approx. 1 min. and be disconnected from the 230 V mains. The polyswitch fuses reset automatically during this period.

Fault	Possible cause	Remedy
Living area battery is not charged during 230 V operation (battery voltage constantly below 13.3 V)	No mains voltage	Switch on the automatic circuit breaker in the vehicle; check the mains voltage
	Too many consumers are switched on	Switch off consumers not required
	Defective electrobloc	Contact the customer service department
Living area battery is overcharged during 230 V operation (battery voltage constantly above 14.5 V)	Defective electrobloc	Contact the customer service department

Fault	Possible cause	Remedy
Starter battery is not charged during 230 V operation (battery voltage constantly below 13.0 V)	No mains voltage	Switch on the automatic circuit breaker in the vehicle; check the mains voltage
	Too many consumers are switched on	Switch off consumers not required
	Defective electrobloc	Contact the customer service department
Living area battery is not charged during mobile operation (battery voltage below 13.0 V)	Defective alternator	Check the alternator
	No voltage on D+ input	Check the fuse and wiring
	D+ switch on the electrobloc is set incorrectly.	Set the switch according to the D+ signal from the vehicle (12 V or active ground)
	Defective electrobloc	Contact the customer service department
The living area battery is overcharged during mobile operation (battery voltage constantly above 14.3 V)	Defective alternator	Check the alternator
The refrigerator does not work during mobile operation	No power supply to the refrigerator	Check the fuse (20 A of supply; possibly 1A of D+ signal) and wiring
	Defective electrobloc	Contact the customer service department
	Defective refrigerator	Check the refrigerator
Solar loading does not work	Solar charge regulator not plugged in	Plug in solar charge regulator
	Defective fuse or wiring	Check fuse and wiring
	Solar charge regulator defective	Check solar charge regulator
12 V supply does not work in the living area	12 V main switch for the living area battery is switched off	12 V main switch for the living area battery must be switched on
	Not all plugs or fuses are plugged in on the electrobloc	plug in all plugs and fuses (correct values!) on the electrobloc
	Defective fuse or wiring	Check fuse and wiring
	Defective electrobloc	Contact the customer service department



- ▲ If the device becomes too hot due to excessive ambient temperature or lack of ventilation, the charging current is automatically reduced. Nevertheless, always prevent the device from overheating.
- ▲ If the automatic shutdown mechanism of the battery monitor is triggered, fully charge the living area battery.

3.4 Closing down the system

A battery is isolated by switching off the main switch on the IT .../LT ... control and switch panel and by disconnecting a plug connector.



▲ ATTENTION!

Total discharge.

Damage to the living area battery:

- Fully charge the living area battery before and after closing down the system. (Connect vehicle to the mains with an 80-Ah-battery at least 12 hours and with a 160-Ah-battery at least 24 hours).

Closing down Disconnect the living area battery from the 12 V power supply if the motor-home is not used for a longer period (during the winter for example).

- ▶ Fully charge the living area battery before closing down the system.
- ▶ Disconnect battery terminal

The living area battery is then protected against total discharge. This only applies if the battery is intact. Follow the instructions provided by the battery manufacturer.

- ▶ Remove the "+ solar cell" connector on the solar charge regulator (if available).

4 Application and functions in detail

The EBL 267 A electrobloc is the central power supply unit for all 12 V consumers in the vehicle's electrical system. It is usually located in a cupboard or storage space and is accessible from the front in order to change fuses.

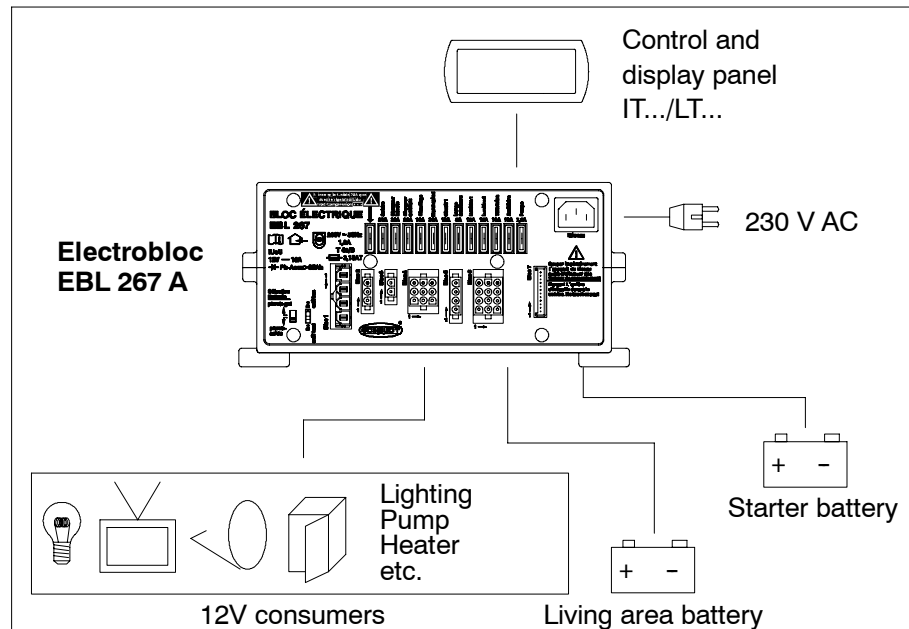

Fig. 2 On-board power supply system

Modules The EBL 267 A electrobloc contains:

- a charger module for charging all connected batteries
- the complete 12 V distribution
- the fuses for the 12 V circuits

System devices An IT ... or LT ... control and switch panel must be connected for operation. These devices control the electrical functions in the vehicle's living area, including accessories.

There is also a connection for an additional charger and a solar charge regulator.

Flat vehicle fuses protect the various circuits. Exceptions are the two D+ outputs. These are protected by a Polyswitch fuse):

- Charger module protective circuits**
- Excess temperature
 - Overload
 - Short circuit

Mains connection 230 V AC \pm 10 %, 47 to 63 Hz sinusoidal, protection class I

Current-carrying capacity 12 V outputs may be loaded with max. 90% of the rated current of the respective fuse (also see front panel).

4.1 Battery functions

Suitable batteries	6-cell lead-acid or lead-gel batteries, 55 Ah and above	
Battery charging during mobile operation	Simultaneous charging of the starter battery and the living area battery via the alternator, parallel connection of the batteries via a cut-off relay	
Battery isolation	<p>A battery is isolated as follows:</p> <ul style="list-style-type: none"> ▶ Switch off the 12 V main switch on the control and switch panel. ▶ Pull out flat vehicle fuse, refrigerator (fig. 3, pos. 11) if available ▶ Pull out connector on block 4 of the EBL 267 A. <p>This prevents the living area battery from slowly discharging due to closed circuit current while the vehicle is not in use.</p>	
Battery selector switch	The switching option provided by the battery selector switch ensures optimum charging of the two battery types, lead-gel and lead-acid.	
Standby current from living area battery (without consumer currents)	<p>With LT control and switch panel : approx. 4 mA (depending on the control and switch panel being used) under the following conditions:</p> <ul style="list-style-type: none"> ● No mains connection ● Living area battery voltage 12.6 V ● 12 V main switch "OFF" 	
Battery charging via mains connector	Living area battery	
	Characteristic charging curve	IUoU
	Final charge voltage	14.3 V
	Charge current	18 A
	Voltage for float charge	13.8 V with automatic switch function
	Starter battery	
	Charging current float charge	max. 2 A

4.2 Additional functions

- Automatic switch function for AES/compressor refrigerator** This relay supplies the AES/compressor refrigerator with power from the starter battery when the vehicle engine is running and the D+ connection is live. An AES refrigerator is powered by the living area battery when the vehicle engine is not running.
- Awning light** The power supply to this consumer is automatically interrupted as soon as the engine starts running (the D+ connection is live in this case or switched to ground, depending on the type of vehicle). The awning light can still be used even if the 12 V power supply is switched off.
- D+ signal** The conventional D+ signal (D+ connection is live when the engine is running) is evaluated directly.
An integrated D+ converter enables the connection of vehicles for which the D+ signal is provided as an active ground signal (e.g. FIAT).
A selector switch on the electrobloc specifies which D+ signal is to be evaluated.
- Mains charging of the starter battery** This feature provides an automatic max. 2 A float charge for the starter battery when the 230 V mains is connected to the electrobloc.

5 Maintenance

- The EBL 267 A electrobloc is maintenance free.
- Cleaning** Clean the electrobloc with a soft, slightly damp cloth and mild detergent. Never use spirit, thinners or similar substances. Do not allow liquids to enter the electrobloc.

© No part of this manual may be reproduced, translated or copied without express written permission.

Appendix

A EC Declaration of Conformity

Schaudt GmbH hereby confirms that the design of the EBL 267 A electro-bloc complies with the following relevant regulations:

EC-Low Voltage Directive

2006/95/EC dated 12.12.2006

Directive on electromagnetic compatibility

2004/104/EC dated 14.10.2004

2005/49/EC dated 25.07.2005

and

2005/83/EC dated 23.11.2005

The original EC Declaration of Conformity is available for reference at any time. This declaration is based on:

Typgen. no.: e1*72/245*95/54*3965*06

EC-gen. mark.: e1 023965

Manufacturer Schaudt GmbH, Elektrotechnik & Apparatebau

Address Planckstrasse 8
88677 Markdorf
Germany

B Special fittings/accessories

Switch panel Schaudt IT .../LT ... switch panel (required for operation)

C Customer service

Customer service address Schaudt GmbH, Elektrotechnik & Apparatebau
Planckstrasse 8
D-88677 Markdorf

tel.: +49 7544 9577-16 e-mail: kundendienst@schaudt-gmbh.de

Office hours Mon to Thurs 08.00 – 12.00, 13.00 – 16.00
Fri 08.00 – 12.00

Send in the device Returning a defective device:

- ▶ Fill in and enclose the fault report, see Appendix D.
- ▶ Send it to the addressee (free of charge).

D Fault report

In the event of damage, please return the defective device together with the completed fault report to the manufacturer.

Device type: _____
Article no.: _____
Vehicle: _____ Manufacturer: _____
Model: _____
Own installation? Yes No
Upgrade? Yes No
Upstream overvoltage protection? Yes No

Following fault has occurred (please tick):

- Electrical consumers do not work - which?
(please specify below)
- Switching on and off not possible
- Persistent fault
- Intermittent fault/loose contact

Other remarks:

E Layout

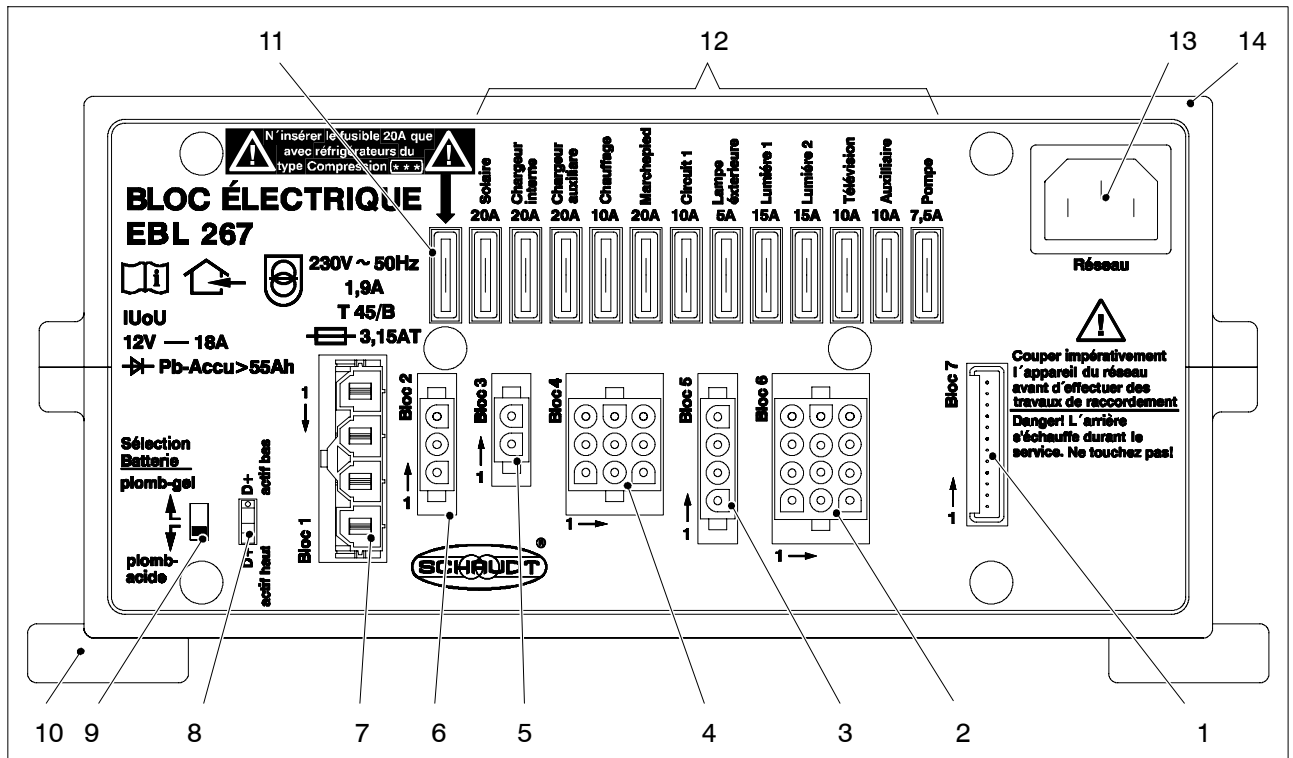

Fig. 3 Layout of the EBL 267 A electrobloc (front)

- | | |
|--|--|
| 1 Connection for IT .../LT .. control and switch panel | 8 D+ signal selector switch |
| 2 Connector block, D+ (output), consumers connected | 9 Selector switch for acid/gel battery |
| 3 Connector block, D+ (input), battery sensor | 10 Assembly flaps |
| 4 Connector block, Spare, consumers not connected | 11 Fuse, AES/compressor refrigerator |
| 5 Connector block, additional charger | 12 Flat vehicle fuses |
| 6 Connector block, solar regulator | 13 mains connector |
| 7 Connector block, refrigerator | 14 Housing |

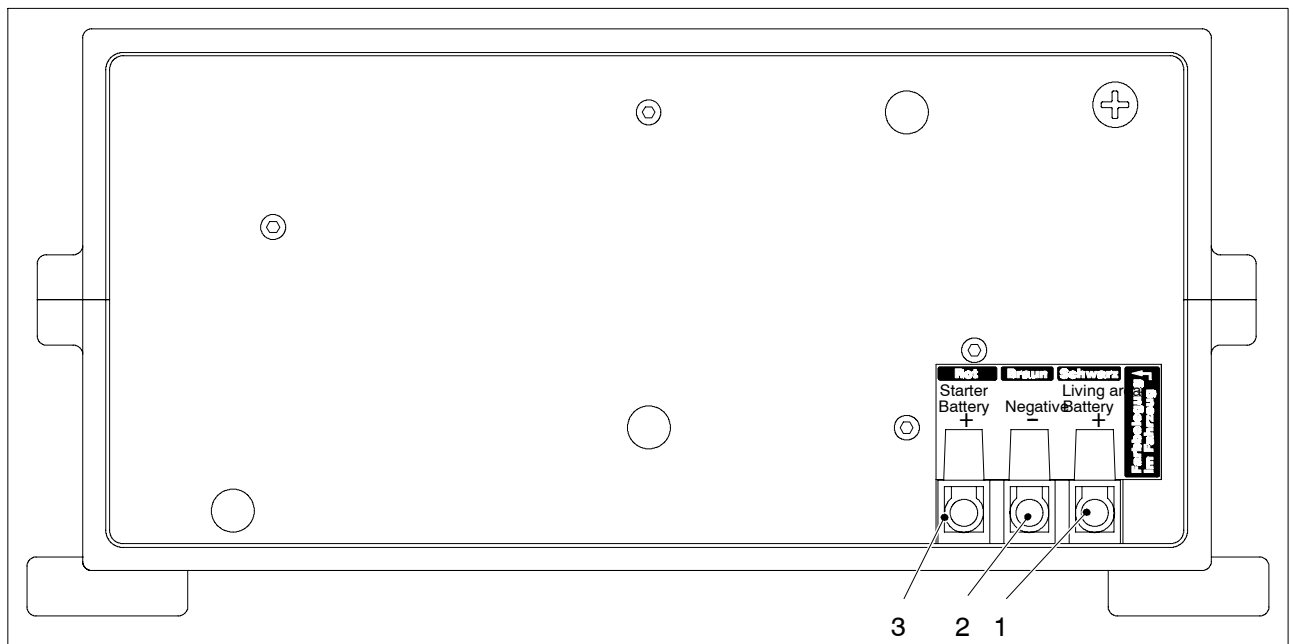

Fig. 4 Layout of EBL 267 A electrobloc (rear)

- | | |
|-----------------------------------|-------------------------------|
| 1 Connection, living area battery | 3 Connection, starter battery |
| 2 Connection, earth | |

F Block diagram/connection diagram

